

CRANE SCALE

1...15Ton

Functions



CSBH



◆Special design:
Used under high temperature environment

◆Multi-weighing units:
Kg, lb, N are selectable, generally kg is the default unit.

◆Multi-function operation:
Tare, Zero, Auto zero tracking, Total, Hold;
Overload warning and record,
Operate through remote controller, etc

◆User-friendly design:
Cast aluminum housing for maximum protection;
Large red 5 digit LED display (digit height 30mm);
Battery Operated with low battery indication;
Automatic turn off , power-saving function.

Dimensions

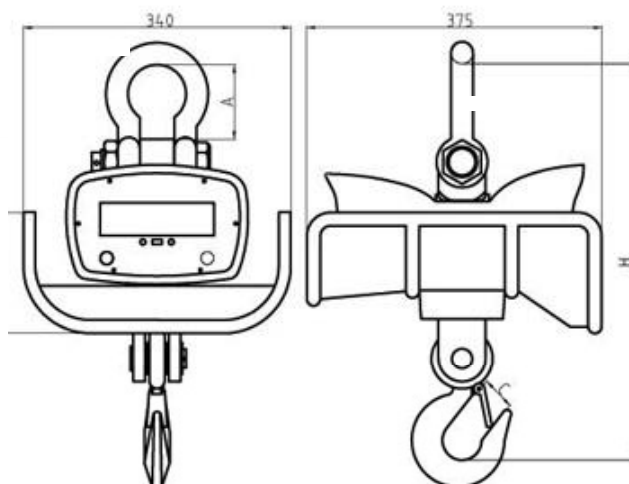

Capacity	A(mm)	C(mm)	H(mm)	N.W.(Kg)
1000Kg	67	33	450	18.5
2000Kg	95	40	510	22
3000Kg	113	50	625	31
5000Kg	122	60	710	43
10000Kg	144	70	835	60
15000Kg	166	85	900	73

Min Distance Between Scales and Temperature			
1000°C	1200°C	1400°C	1600°C
1.6m	1.8m	2.0m	2.2m

MODEL	CAPACITY (Kg)	DMSION(Kg)	Min WEIGH (Kg)	RESOLUTION
CSBH1000	1000	0.5	10	1/2000
CSBH2000	2000	1	20	1/2000
CSBH3000	3000	1	20	1/3000
CSBH5000	5000	2	40	1/2500
CSBH10000	10000	5	100	1/2000
CSBH15000	15000	5	100	1/3000