

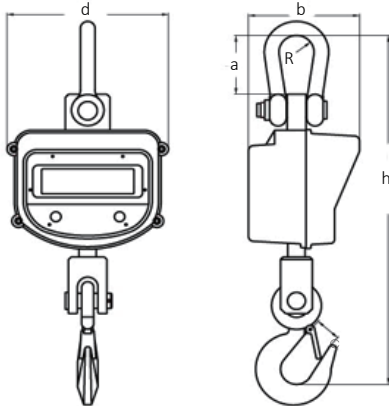

E380 Palm Indicator



| Models | a   | b   | c  | d   | d   | R  |
|--------|-----|-----|----|-----|-----|----|
| CSA1k  | 95  | 180 | 28 | 264 | 570 | 27 |
| CSA3k  | 95  | 180 | 35 | 264 | 580 | 27 |
| CSA5k  | 124 | 188 | 40 | 264 | 665 | 39 |
| CSA10k | 124 | 206 | 48 | 264 | 745 | 45 |

**Power**

110V or 220V - 9V1Ah adaptor

**Battery**

Battery: 6V7Ah - 70hrs working time

**Capacity**

1000 - 10000kg

**Accuracy**

Class III

**Housing**

Aluminum alloy

**IP Rate**

IP54

**Safety Load**

125% F.S.

**Ultimate Load**

400% F.S.

**Models**

| Part No.         | 100610          | 100611          | 100612          | 100613            |
|------------------|-----------------|-----------------|-----------------|-------------------|
| Models           | CSA1K           | CSA3K           | CSA5K           | CSA10K            |
| <b>U.P.(USD)</b> | <b>\$740.00</b> | <b>\$760.00</b> | <b>\$860.00</b> | <b>\$1,180.00</b> |
| Capacity         | 1000kg          | 3000kg          | 5000kg          | 10000kg           |
| Division         | 500g            | 1kg             | 2kg             | 5kg               |
| Weight           | 12kg            | 13kg            | 21kg            | 30kg              |

**Display**

1" LED (30mm)

**Stable Time**

≤10s

**Unit**

kg | lb | N

**Zero Range**

4% F.S.

**Tare Range**

100% F.S.

**Output**

Bluetooth (optional)

**Operating Temperature**

-20°C - 50°C

**Remote Control Distance**

&lt; 15m

**Battery for R.C.**

2 x AA 1.5V

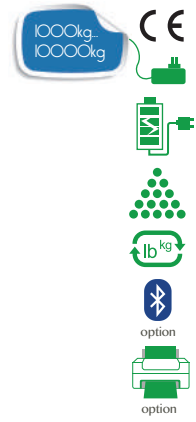
**Aluminum Alloy Housing**

- Rugged aluminum alloy housing
- Zinc coated shackle, safe lock
- Zinc coated 360° swivel hook
- Big 1.2" LED display
- Rechargeable 6V7Ah battery
- Remote control included
- Remote distance <15m
- Big capacity till 10000kg
- 2 direct metal keys
- Tare range: 100%F.S.
- Multi-units exchange: kg/lb
- Auto zero tracking
- Hold function
- Overload warning
- Power saving mode
- Stable time ≤10s

**Accessories**

- Wireless remote display - E-MDS
- Palm indicator - E380 model
- Bluetooth output - for Hscaler2
- Bluetooth printer - RP01



| List          |                 |
|---------------|-----------------|
| Date:         | 2017-02-11      |
| Time:         | 12:12:07        |
| CN:           | 00              |
| No.:          | 0001            |
| N.W.:         | 75kg            |
| List          |                 |
| CN:           | 00              |
| No:0001       | 75kg 2017-02-11 |
| No:0002       | 80kg 2017-02-11 |
| No:0003       | 78kg 2017-02-11 |
| No:0004       | 82kg 2017-02-11 |
| Total times:  | 0004            |
| Total weight: | 315kg           |