



# CST TABLE WEIGH SCALE

[www.hiweigh.com](http://www.hiweigh.com)
[info@hiweigh.com](mailto:info@hiweigh.com)

Tel: +86-21-58250298

Fax: +86-21-58273591

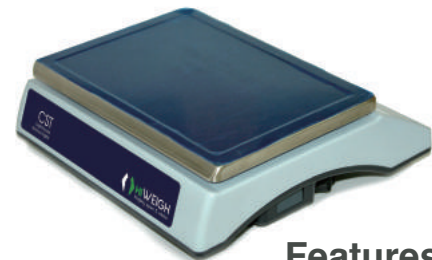

## TechnicalData

<b>Power</b> 100-240V - 12V1A adaptor Rechargeable Battery: 6V4Ah Estimated working time: 320hrs - no backlit 120hrs - backlit Charge Time: 3hrs	<b>Display</b> LCD (30mm)  <b>Units</b> Kg   lb   g   oz  <b>Sampling Speed</b> 15 times/second (7.5   30 for selection)	<b>Operating Temperature</b> -10°C - 40°C  <b>Storage Temperature</b> -25°C - 55°C  <b>Relative Humidity</b> ≤80% non-condensing
<b>Pan Dimensions</b> 310 x 220mm	<b>Non-linearity</b> ≤0.01%F.S.	<b>Approval</b> CE EC Type (DK0199.403)
<b>Capacity</b> 3   6   15   30Kg	<b>Power Consumption</b> 12mA - no backlit 36mA - with backlit 48mA - with backlit   RS232	<b>RS232</b> Optional
<b>Display Resolution</b> 1/3,000   1/30,000		
<b>Net Weight</b> 3.8Kg  <small>dimension in mm</small>		

## Features

- Rugged ABS housing <
- Big s.s pan 310 x 220mm <
- EC Type approved - CST\*M <
- Big LCD display with backlit <
- Rechargeable 6V battery <
- 320hrs operating time (no backlight) <
- High accuracy of 1/30,000 <
- approved model till 1/3,000 only <
- Aluminum load cell supporter <
- Single or dual range setup <
- 22 operating keys <
- Checkweigh function <
- Counting function <
- Full capacity tare <
- Accumulation function <
- Accumulation recall <
- Gravity value set <
- Hold function <
- Auto power off <
- RS232 optional <
- Bluetooth optional <
- WiFi optional <

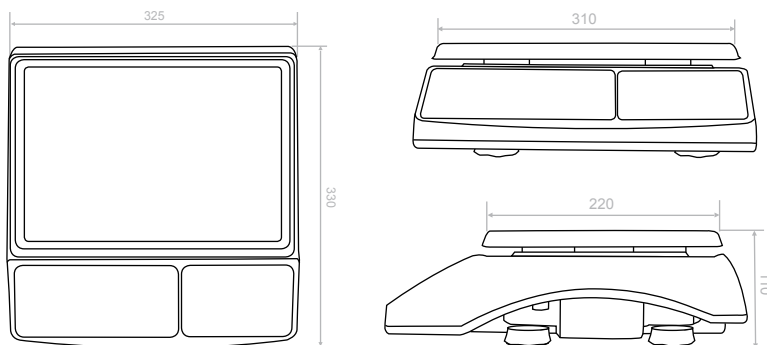

## Models

Part No.	100858	100859	100860	100861	100862	100863	100864	100865
Models	CST3	CST6	CST15	CST30	CST3M	CST6M	CST15M	CST30M
U.P.(USD)	\$200.00	\$200.00	\$200.00	\$200.00	\$244.00	\$244.00	\$244.00	\$244.00
Capacity	3kg	6kg	15kg	30kg	3kg	6kg	15kg	30kg
Division	0.1g	0.2g	0.5g	1g	1g	2g	5g	10g
Pack Size	75 x 45 x 34cm (4pcs)							
Weight	17kg (4pcs)							