

IWM

VALUE EACH GRAM  
HiWEIGH

## SPECIFICATIONS

Material: Cast iron

Capacity: 100-2000kg

Class: OIML M1-2

## FEATURES

- Smart design with handle and feet  
(Easy to lift and move)
- Optional ISO17025 certificate



## MODELS

Model	Part No.	Capacity	Division
IWM100	110111	100kg	OIML M1-2
IWM200	110112	200kg	OIML M1-2
IWM500	110113	500kg	OIML M1-2
IWM1000	110114	1000kg	OIML M1-2
IWM2000	110115	2000kg	OIML M1-2

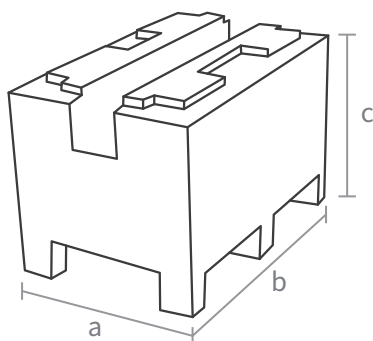

## DIMENSION / mm

Capacity	a	b	c
100kg	280	225	340
200kg	315	340	465
500kg	315	500	750
1000kg	500	500	750
2000kg	500	750	1000

+86-512-67317873 | www.hiweigh.com | info@hiweigh.com