

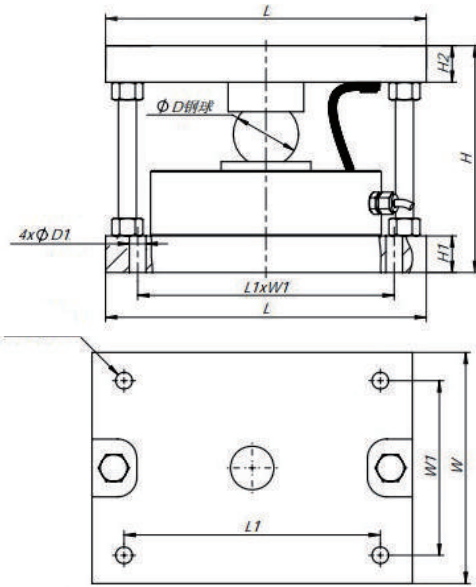

M8K

- > Alloy steel material
- > Suitable for M8R load cells
- > Big capacity up to 60Ton
- > Suitable for weighbridge and weighing systems
- > With anti-lightening cable

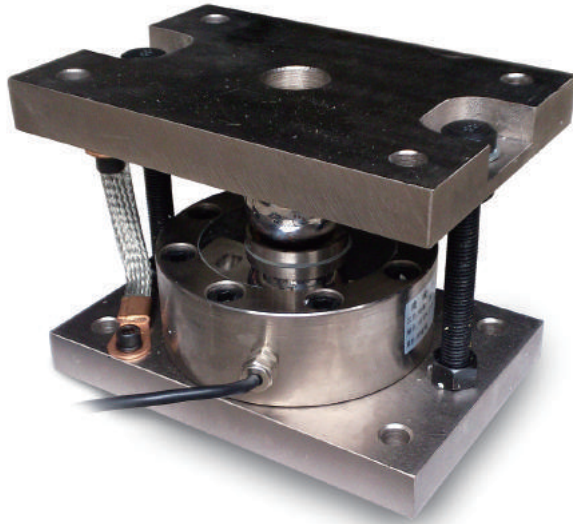

Capacity	L	L1	W	W1	ΦD1	ΦD2	H1	H2	H
0.5-3t	184	150	124	90	25.4	13	18	18	97.2
5-10t	184	150	124	90	38.1	13	24	24	151.9
15-30t	210	170	142	103	50.8	13	24	24	158
40-60t	250	200	180	136	50.8	13	28.5	28.5	177

Models

Part No.	120321	120322	120323	120324
Models	M8K-3	M8K-10	M8K-30	M8K-60
U.P.(USD)	\$600.00	\$740.00	\$900.00	\$1,000.00
Capacity	0.5-3t	5-10t	15-30t	40-60t
Material	Alloy Steel			

M5K

- > Alloy steel material (s.s material optional)
- > Suitable for M5 serials load cells
- > Anti-overloading design
- > Anti-overturn design
- > Easy installation

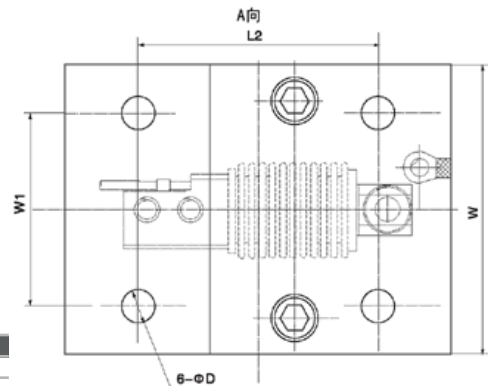
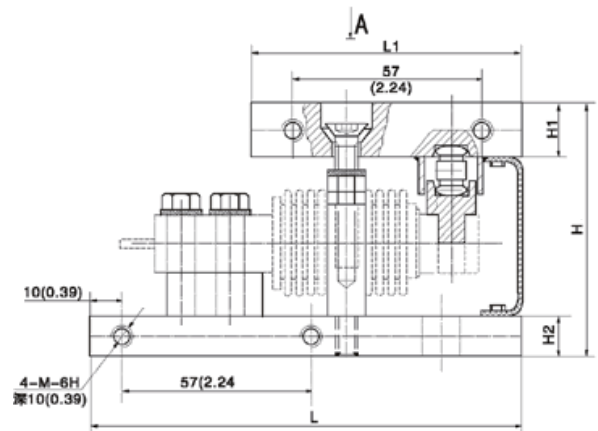
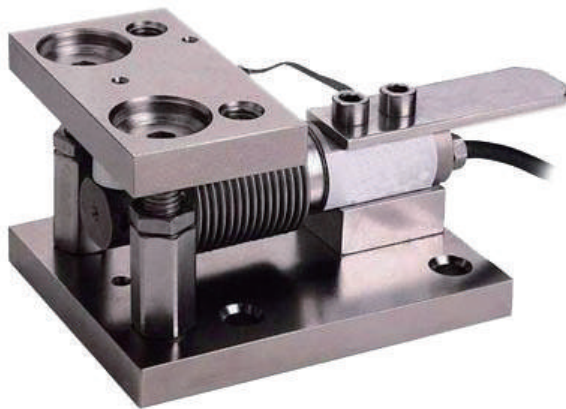

Capacity	H	H1	H2	L	L1	L2	W	W1	D	M
10-200kg	77	12	12	130	75	95	90	60	9	M5
300-1000kg	90	20	15	160	100	100	120	80	14	M8

Models

Part No.	120325	120326
Models	M5K-200	M5K-1000
U.P.(USD)	\$360.00	\$440.00
Capacity	10-200kg	300-1000kg
Type	Alloy Steel	

Value Each Gram A professional weighing products manufacturer and supplier

Fax: +86-21-58273591

Tel: +86-21-58250298

info@hiweigh.com

www.hiweigh.com