

SPECIFICATIONS

Capacity 50-60000kg	Sensitivity 2.0±0.001mV/V	Insulation Resistance ≥5000mΩ	Temperature Effect Zero ±0.02% F.S. / 10°C
Material Alloy steel	Overload Limitation 150%F.S.	Input Resistance 775±5Ω	Temperature Effect Sensitivity ±0.02% F.S. / 10°C
Protection IP67/IP68	Creep (30 Min) ±0.02% F.S.	Output Resistance 700±2Ω	Operating Temperature -30-70°C
Accuracy C3	Zero Output ±1% Emax	Recommended Excitation 5-18VDC	

FEATURES

- Large capacity up to 60000kg
- Alloy steel material
- M8T with screw fixing kit
- M8R with ball cup
- Suitable for weighbridge and other weighing systems



MODELS

Part No.	120255	120256	120257	120258	120259	120260	120261	120262	120263
M8T	500kg	1t	2t	3t	5t	10t	20t	30t	50t
Part No.	120264	120265	120266	120267	120268	120269	120270	120271	120272
M8R	500kg	1t	2t	3t	5t	10t	20t	30t	50t
Class	C3								
IP	IP67/IP68								

M8T

DIMENSION / mm

Capacity	H	H1	M	L	L1	φA	φB	weight/kg
0.5-3t	62.8	18	M16x1.5	130	104	32	11	1.5
5-10t	84.8	23	M32x1.5	121	98.8	42	11	2
15-30t	90.2	23	M40x1.5	142	116	51	11	3.7
40-60t	102	23	M32x1.5	180	147	67.5	13	5

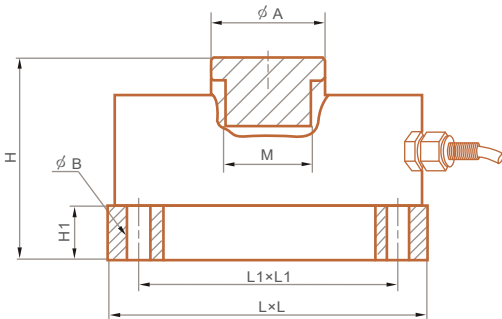

M8R

DIMENSION / mm

Capacity	H	H1	H2	L	L1	φA	φB	φC	φD	weight/kg
0.5-3t	90.2	11	18	130	104	20	32	11	25.4	1.5
5-10t	129	8	23	121	98.8	20	49	11	38.1	2
15-30t	143	8	23	142	116	20	59	11	50.8	3.7
40-60t	155	11	23	180	147	30	63	13	50.8	5

