

SPECIFICATIONS

Capacity 10-40t	Sensitivity 2.0±0.002mV/V	Creep (30 Min) ±0.02% F.S.	Input Resistance 775±5Ω - M9 700±7Ω - M9M
Material Alloy steel	Overload Limitation 150% F.S.	Zero Output ±1% Emax	Recommended Excitation 5-12VDC
Protection IP68	Output Resistance 700±5Ω	Temperature Effect Zero ±0.02% F.S. / 10°C	Operating Temperature -35-65°C
Accuracy C3	Insulation Resistance ≥5000mΩ (100VDC)	Temperature Effect Sensitivity ±0.02% F.S. / 10°C	

FEATURES

- Analog M9 M9M load cell
- Digital M9D load cell
- M9M with OIML approval
- Large capacity up to 40t
- Alloy steel material
- Heavy-duty structure with mounting cup
(Easy to center by itself)
(Easy to install and maintain)
- Suitable for weighbridge, rail scales, etc.
- Default cable length is 12m
(Optional 16m/20m cable)



MODELS

Part No.	120273	120274	120275	120276
M9	10t	20t	30t	40t
Part No.	120277	120278	120279	120280
M9D	10t	20t	30t	40t
Part No.	120281	120282	120283	120284
M9M	10t	20t	30t	40t
Class	C3/N5			
IP	IP68			

M9M

DIMENSION / mm(inch)

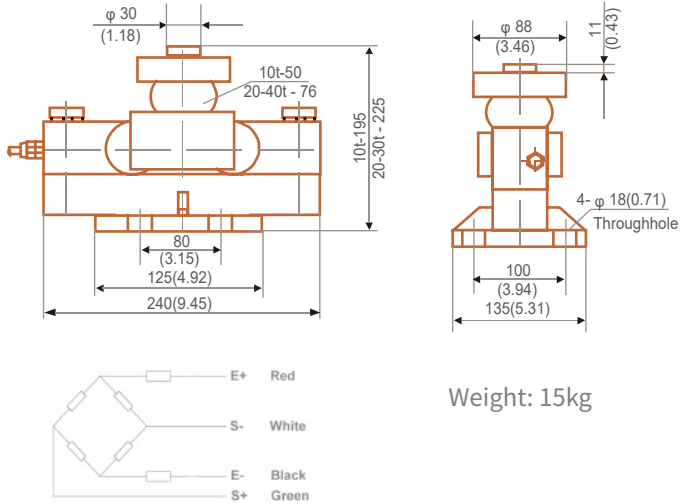

Weight: 15kg



M9 M9D

DIMENSION / mm

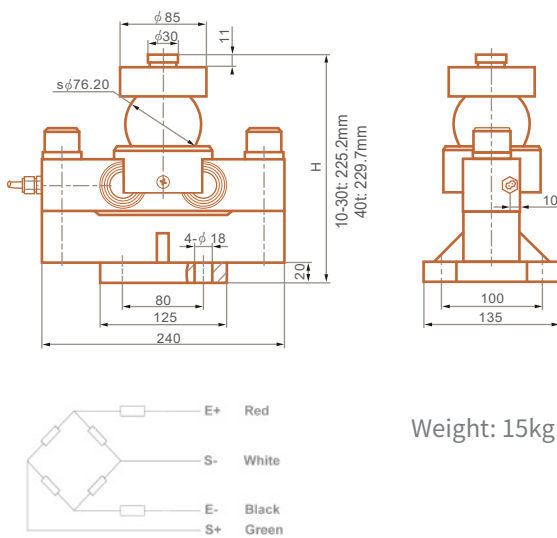

Weight: 15kg

