

SPECIFICATIONS

Capacity: 5/10/20kg

Density: 7.9g/cm³

Susceptibility: <0.05

Magnetization: SCWF1 ≤ 25μt

SCWF2 ≤ 80μt

SCWM1 ≤ 250μt



FEATURES

- Optimal aluminum box



SCW

VALUE EACH GRAM
HIWEIGH

MODELS

Model	Part No.	Capacity	Division
SCWF105	110089	5kg	OIML F1
SCWF110	110090	10kg	OIML F1
SCWF120	110091	20kg	OIML F1
SCWF205	110092	5kg	OIML F2
SCWF210	110093	10kg	OIML F2
SCWF220	110094	20kg	OIML F2
SCWM105	110095	5kg	OIML M1
SCWM110	110096	10kg	OIML M1
SCWM120	110097	20kg	OIML M1

DIMENSION / mm

Capacity	a	b	c
5kg	148	75	84
10kg	192	95	106
20kg	228	115	135

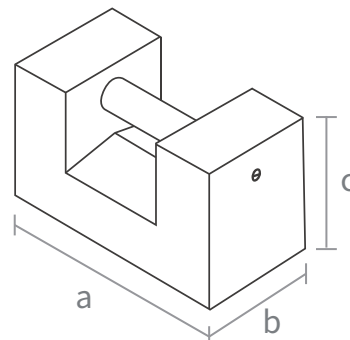

+86-512-67317873 | www.hiweigh.com | info@hiweigh.com