

SUS304 Structure

SUS304 stainless steel material
Suitable for monorail and other tracks
2 different length for selection
- customized size available
Capacity up to 1000kg
Cable or wireless connection
Optional galvanized structure

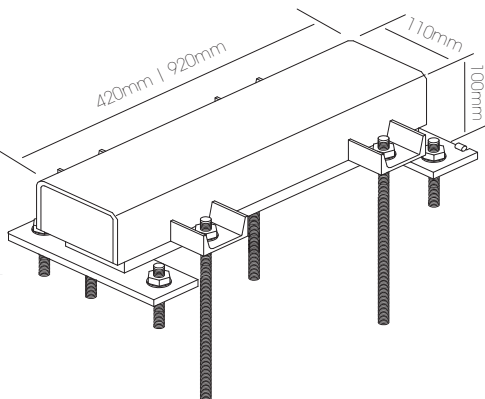

M17 | M28 LoadCell

M17 - aluminum alloy material, IP65
M28 - alloy steel material, IP67
OIML approved load cell optional

Optional K7s Indicator



Big backlit FSTN LCD display, the weight can be read clearly even in the sun. SUS304 s.s IP66 housing, suitable for harsh environment, with rechargeable battery, 100-240v power source directly, kg/lb unit exchange, animal weighing function, accumulating, hold, x10 accuracy, counting, zero, tare, printing, etc. Default with 2 RS232 connector, options of Bluetooth or WiFi.

Optional X5FM Indicator



Stainless steel bracket, easy for wall mounting, red LED display, with built-in rechargeable battery, animal weighing function, hold, accumulating, kg/lb units, x10 accuracy, counting, zero, tare, printing, etc. Default with RS232 connector, option of Bluetooth or WiFi.

Accessories

Washdown printer - P902
S.S remote display - MDSS



Power
100-240V 50/60Hz Adaptor
Rechargeable Battery:
K7s - 6V1.2Ah
X5FM - 6V2.8Ah

Length
420mm | 920mm
- customized length available

Capacity
150 - 1000Kg

Load Cell & Approval
M17 - IP65
M28 - IP67

Display
K7s - FSTN LCD - 37mm
X5FM - LED - 20mm

Units
K7s - Kg/lb | g/oz
X5FM - Kg/lb

Output
K7s - RS232 * 2
X5FM - RS232
- optional Bluetooth
- optional WiFi

Operating Temperature
-10°C - 40°C

Approval
CE

Models *Prices not include indicators

Part No.	100638	100639	100640	100641	100642
Models	SLS150	SLS300	SLS300L	SLS600	SLS1000
U.P.(USD)	\$840.00	\$840.00	\$1,560.00	\$1,560.00	\$1,560.00
Capacity	150kg	300kg	300kg	600kg	1000kg
Division	50g	100g	100g	200g	500g
Length	420mm		920mm		
Weight	20kg		52kg		