

Features

- > Stainless steel housing
- > Transparent dust cover
- > Stainless steel pan 230x190mm
- > Waterproof AC/DC adaptor
- > Rechargeable 6V battery
- > New load cell protection
- > IP68 protection
- > 4 adjusting feet
- > Perfect for food processing fields:
meat/fish/vegetable/fruit, etc.
- > Suitable for chemistry,
- > TI high accuracy A/D chips
- > Double red LED display
- > 4 function keys
- > 12 function indications
- > High accuracy till 1/15,000e
- > Multi-units exchange
- > Checkweigh function
- > Battery volume indication
- > Counting function

TechnicalData

Power 110V/120V or 220V/240V Rechargeable Battery: 6V4Ah	Display 6 digits 0.8" LED
Pan Dimensions: 230x190mm	Units Kg lb g oz pcs
Capacity: 3 6 15 30Kg	Function Keys: On Off(Zero) Tare Set
Division: 0.2 0.5 1 2g	Operating Temperature -5°C - 35°C
Protection: IP68	Approval CE

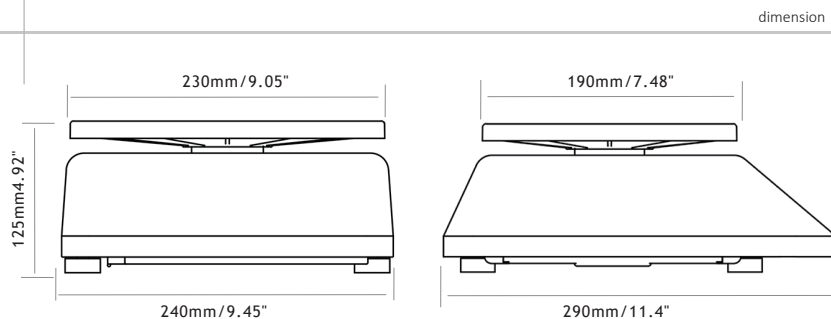

Models

Part No.	100805	100806	100807	100808
Models	SUPER3	SUPER6	SUPER15	SUPER30
U.P.(USD)	\$288.00	\$288.00	\$288.00	\$288.00
Capacity	3kg	6kg	15kg	30kg
Division	0.2g	0.5g	1g	2g
Pack Size	700 x 360 x 320mm (4pcs)			
Weight	20kg (4pcs)			