

TechnicalData

Power 100-240V - 12V1A adaptor Rechargeable Battery: 6V4Ah	Display LED (green)	Operating Temperature -10°C - 40°C
Pan Dimensions 310 x 220mm	Units Kg lb Liter	Storage Temperature -25°C - 55°C
Capacity 3 6 15 30kg	Non-linearity ≤0.01%F.S.	Relative Humidity ≤80% non-condensing
Display Resolution 1/15,000	RS232 Optional	Approval CE
Internal Resolution 200,000	Net Weight 3.8Kg	

Features

- > Rugged ABS housing
- > Stainless steel pan 310x220mm
- > Bright green LED display
- > W5*H model with pole display
- > Rechargeable 6V battery
- > High accuracy of 1/15,000
- > Aluminum load cell supporter
- > Five operating keys
- > Counting function
- > Zero/Tare function
- > Accumulation function
- > Display speed adjust
- > Display brightness adjust
- > Liter conversation factor
- > Auto power off
- > RS232 optional

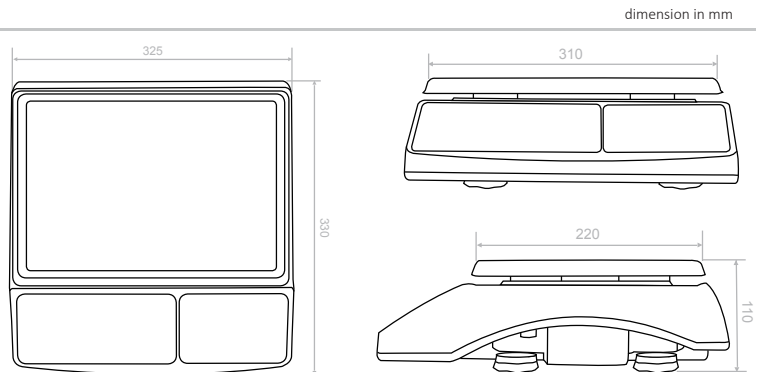
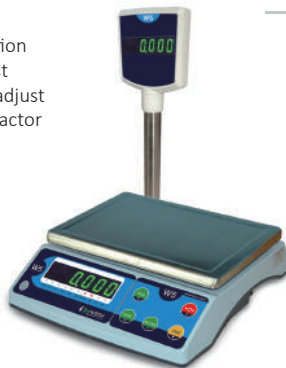

Models

Part No.	100866	100867	100868	100869	100870	100871	100872	100873
Models	W503	W506	W515	W530	W503H	W506H	W515H	W530H
U.P.(USD)	\$144.00	\$144.00	\$144.00	\$144.00	\$168.00	\$168.00	\$168.00	\$168.00
Capacity	3kg	6kg	15kg	30kg	3kg	6kg	15kg	30kg
Division	0.2g	0.5g	1g	2g	0.2g	0.5g	1g	2g
Pole	No				Yes			
Pack Size	75 x 45 x 34cm (4pcs)				78 x 45 x 35cm (4pcs)			
Weight	17kg (4pcs)				21kg (4pcs)			

Value Each Gram A professional weighing products manufacturer and supplier

Tel: +86-21-58273591 Fax: +86-21-58273591

Tel: +86-21-58250298

www.hiweigh.com info@hiweigh.com

www.hiweigh.com