

## Technical Data

<b>Power</b> 100-240V - 12V1A adaptor Rechargeable Battery: 6V4Ah	<b>Display</b> LCD (30mm)	<b>Operating Temperature</b> 0°C - 40°C
<b>Pan Dimensions</b> 310 x 220mm	<b>Units</b> Kg   lb   Liter	<b>Storage Temperature</b> -25°C - 55°C
<b>Capacity</b> 3   6   15   30Kg	<b>Sampling Speed</b> 10 times/second	<b>Relative Humidity</b> ≤80% non-condensing
<b>Display Resolution</b> 1/15,000	<b>Non-linearity</b> ≤0.01%F.S.	<b>Approval</b> CE
<b>Sensitivity</b> 1.2 - 3mv/V	<b>Net Weight</b> 3.85kg	<b>RS232</b> Optional

dimension in mm

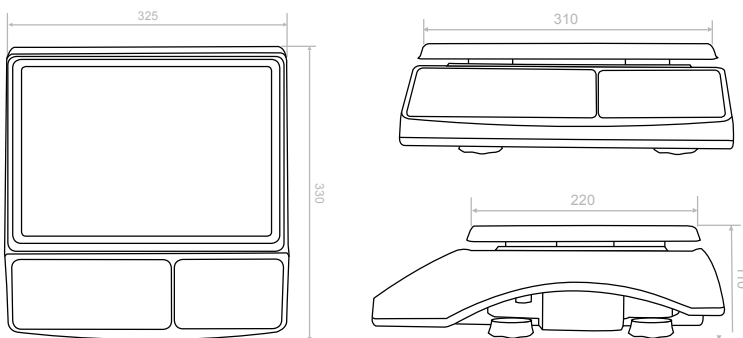

## Features

- < Rugged ABS housing
- < Stainless steel pan 310x220mm
- < Bright LCD display with backlit
- < Rechargeable 6V battery
- < High accuracy of 1/15,000
- < Aluminum load cell supporter
- < Five operating keys
- < Counting function
- < Zero/Tare function
- < Accumulation function
- < Display speed adjust
- < Display brightness adjust
- < Liter conversion factor
- < Auto power off
- < RS232 optional

## Models

Part No.	100874	100875	100876	100877
Models	W703	W706	W715	W730
<b>U.P.(USD)</b>	<b>\$140.00</b>	<b>\$140.00</b>	<b>\$140.00</b>	<b>\$140.00</b>
Capacity	3kg	6kg	15kg	30kg
Division	0.2g	0.5g	1g	2g
Pack Size	75 x 45 x 34cm (4pcs)			
Weight	17kg (4pcs)			