



Features

- > Rugged ABS housing
- > Stainless steel pan 250x210mm
- > Double bright red LED display
- > Rechargeable 6V battery
- > High accuracy of 1/30,000
- > Aluminum load cell supporter
- > Five operating keys
- > Counting function
- > Zero/Tare function
- > Accumulation function
- > Display speed adjust
- > Display brightness adjust
- > Liter conversation factor
- > Auto power off
- > RS232 optional

TechnicalData

Power 100-240V - 10V/600mA adaptor Rechargeable Battery: 6V4Ah	Display LED (red)	Operating Temperature -10°C - 40°C
Pan Dimensions 250 x 210mm	Units Kg lb Liter	Storage Temperature -25°C - 55°C
Capacity 3 6 15 30Kg	Non-linearity ≤0.01%F.S.	Relative Humidity ≤80% non-condensing
Display Resolution 1/30,000	RS232 Optional	Approval CE
Internal Resolution 200,000	Net Weight 3.6Kg	

dimension in mm

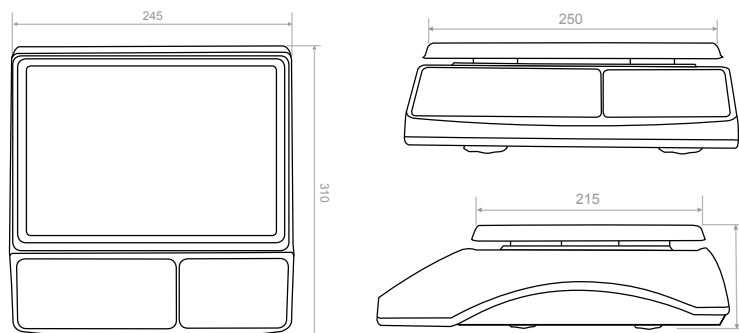

Models

Part No.	100916	100917	100918	100919
Models	WE03	WE06	WE15	WE30
U.P.(USD)	\$128.00	\$128.00	\$128.00	\$128.00
Capacity	3kg	6kg	15kg	30kg
Division	0.1g	0.2g	0.5g	1.0g
Pack Size	36 x 29 x 14cm			
Weight	3.6kg			